

YIFAN



PE PEX Series Jaw Crusher

Leading crushing and screening equipment manufacturer in China

Zhengzhou YiFan Machinery Co.,Ltd(the share-holder is Shande Technology (Beijing) Co., Ltd) has its headquarter in Beijing. It is a famous manufacturer of crushing and screening equipment and provides series stone crusher and crushing equipment for customers.



YIFAN

ZHENGZHOU YIFAN MACHINERY CO.,LTD

Tel:+86 371 64628852 Web : www.yfcrusher.com Add : Zhengyuan Rd, Xinyang, Zhengzhou Henan 450100, China

Zhengzhou YIFAN Machinery Co., Ltd (Shande Technology (Beijing) co., LTD. Is the holding company) is a domestic leading crushing and screening equipment manufacturer and aggregate processing comprehensive solution provider, it researched a kind of high efficient and energy saving crushing equipment.--the large and medium-sized jaw crusher. Jaw crusher is mainly used in various industries, such as mining, smelting, road and railway construction, water conservation and chemical industry etc. PE Series is used in primary crushing, while PEX series is used in secondary crushing and fine crushing.

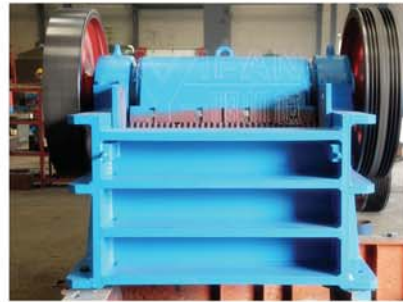

Features and Benefits

1. Simple structure and easy maintenance; Stable performance and low operation; High crushing ratio.
2. The crushing cavity is deep and there is no dead zone, improving the feed capacity and production.
3. High crushing ratio and uniform product particle size.
4. Gasket type discharge gate adjusting device has big adjusting range, increasing the flexibility of equipment.
5. Safe and reliable lubrication system, convenient replacement of parts, easy maintenance.
6. Simple construction , reliable operation and low operating cost.
7. Energy saving: Single energy saving achieves 15%-30%.
8. Wide adjustable range of discharge gate, which can meet different requirements.
9. Low noise, little dust.

Structural Drawing

Jaw crusher mainly consists of frame, eccentric shaft, big pulley, flywheel, movable jaw, side guard plate, toggle, fixed jaw plate and movable jaw plate etc.

Using high strength manganese steel has the features of wear-resistant, resist compression and long life. It is used to crush large, medium, small stones and the corresponding object.

- 1.Frame
- 2.Fixed Jaw Plate
- 3.Movable Jaw Plate
- 4.Movable Jaw
- 5.Eccentric Shaft
- 6.Toggle
- 7.Adjusting Toggle Seat

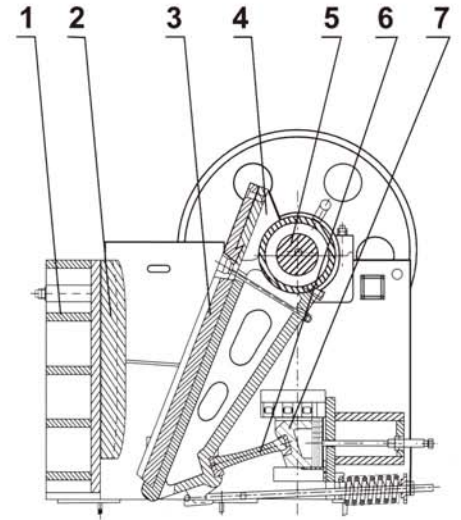

Working Principle

Jaw crusher adopts the electric motor as the power. The eccentric shaft is revolved by an electric motor through v-belts. It causes the swing jaw following the preconcerted path to crush the feeding material. Thus the material will be crushed in the crushing chamber which is composed of the stationary jaw plate, swing jaw plate and the liner plate. The material is discharged from the lower part of machine that is what you want.

Technical Date

Model	Size of Feed Opening(mm)	Max Feed Size(mm)	Discharge Range Opening(mm)	Capacity(m ³ /h)	Motor Power(kw)	Weight(t)
PE-250×400	250×400	210	20-60	3-13	15	2.8
PE-400×600	400×600	340	40-100	10-40	30	6.5
PE-500×750	500×750	425	50-100	28.5-62.5	55	10.8
PE-600×900	600×900	500	65-160	30-75	55-75	15
PE-750×1060	750×1060	630	80-200	80-160	90-110	28.9
PE-870×1060	870×1060	750	170-270	145-235	90-110	29.5
PE-900×1200	900×1200	750	100-200	100-240	110-132	49
PE-1000×1200	1000×1200	850	200-280	190-275	110-132	51
PE-1200×1500	1200×1500	1020	150-300	250-500	200	88.5
PEX-150×750	150×750	120	10-40	5-16	15	2.5
PEX-250×1000	250×1000	210	25-60	10-30	30-37	6.6
PEX-250×1200	250×1200	210	25-60	10-31.5	37	7
PEX-300×1300	300×1300	250	20-90	12.5-53	75	12

Note:The processing capacity is described on the basis of data about processing mid-hard materials and the bulk density of crushed materials is $1.6 \times 10^3 \text{kg/m}^3$.



Overall Dimensions

型号	A	B	C	D	E	F	G	H	I
PE-250×400	1315	938	554	890	812	1450	750	220	735
PE-400×600	1677	1079	640	1190	897	1709	964	295	1125
PE-500×750	1906	1346	820	1270	1200	1890	1370	435	1185
PE-600×900	1840	1380	960	1540	1515	2305	1590	390	1505
PE-750×1060	2540	1840	1140	1800	1600	2740	1940	620	1780
PE-870×1060	2556	1840	1140	1800	1600	2860	2060	620	1780
PE-900×1200	3000	1976	1228	2135	1800	3335	2155	830	2110
PE-1000×1200	3000	1976	1228	2135	1800	3435	2255	830	2110
PE-1200×1500	3152	2352	1416	2410	2285	4618	3040	1100	2410
PEX-150×750	1516	1188	790	625	800	1250	588	190	470
PEX-250×1000	1992	1500	1010	930	900	1530	905	330	850
PEX-250×1200	2192	1700	1220	930	1000	1565	905	330	850
PEX-300×1300	2320	1840	1320	1110	1225	1750	1170	430	1020

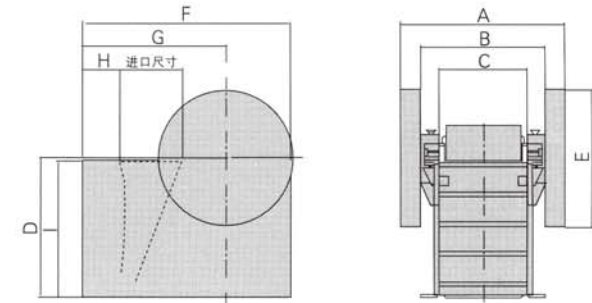

SHANDE TECHNOLOGY (BEIJING) CO.,LTD.
Headoffice Add: Rm422,Nanpeilou Jianshebu,No.11
Sanlihe Rd,Beijing, China
Tel: 010-57811256
Fax: 010-57811257

ZHENGZHOU YIFAN MACHINERY CO., LTD.
Factory Add: Zhengyuan Rd, Xingyang, Zhengzhou Henan
Zip Code: 450100
Tel: +86 371 64628852
Fax: +86 371 64628872
Web: www.yfcrusher.com
E-mail:yifan@yfmac.com

YIFAN